

RECOMMENDED USAGE ⑨ ⑩		
DROPOFF HEIGHT/CONDITION	RECOMMENDED RAIL OPTIONS	* COLOR
< 30" DROPOFF	OPTION "1"	GALVANIZED
≥ 30" DROPOFF, OR ALONG BIKE PATH	OPTION "2"	GALVANIZED
DECORATIVE	OPTION "3"	BLACK

* UNLESS OTHERWISE NOTED ON THE PLANS

ELEVATION VIEW

MANUFACTURING NOTES

- ① PARALLEL TO GROUND.
- ② ONE SHOP SPLICE PER PANEL IS PERMITTED WITH MINIMUM 85 PERCENT PENETRATION. THE WELD MAY BE SQUARE GROOVE OR SINGLE VEE GROOVE. GRIND SMOOTH.
- ③ SHOP SPLICE IS PERMITTED WITH MINIMUM 85 PERCENT PENETRATION. THE WELD MAY BE SQUARE GROOVE OR SINGLE VEE GROOVE. GRIND SMOOTH.
- ④ SEE RAMP DETAILS LOCATED ELSEWHERE IN PLANS FOR RAMP SLOPE AND DIMENSIONS. MAXIMUM RAMP SLOPE WILL NOT EXCEED 8.3 PERCENT. LEVEL LANDING REQUIRED FOR EACH 30" RISE IF GRADE EXCEEDS 5 PERCENT.
- ⑤ 1 1/2" DIA. STANDARD PIPE (1.900" O.D., 0.145" WALL THICKNESS). PARALLEL TO RAMP / SIDEWALK. PROVIDE HOLES AS NEEDED IN 1 1/2" DIA. PIPE FOR GALVANIZING DRAINAGE AND VENTING.
- ⑥ 2 1/2" DIA. STANDARD PIPE (2.875" O.D., 0.203" WALL THICKNESS). SEE "POST MOUNT DETAIL" FOR CRIMPING AND TRIMMING POST TO FIT DIA. OF TOP RAIL. PROVIDE HOLES AS NEEDED IN POST FOR GALVANIZING DRAINAGE AND VENTING. PLUMB ALL POSTS.
- ⑦ SEE "HANDRAIL FABRICATION DETAILS" FOR SPLICE JOINTS.
- ⑧ 5/8" DIA. ROUND BAR EQUAL SPACING AT 4 1/2" MAX. PLUMB ALL PICKETS.
- ⑨ WHEN NEEDED FOR ACCESSIBILITY (GRADE > 5 PERCENT) OR AS NEEDED FOR PEDESTRIAN SAFETY.
- ⑩ NOT TO BE USED ON BRIDGES.
- ⑪ SEE "GENERAL NOTES" FOR ANCHOR BOLT INFORMATION.
- ⑫ BARS S(#3) SPACED AT 12" MAX (SPACED 3" FROM OUTSIDE EDGE OF OVERALL LENGTH OF RAMP/SIDEWALK).
- ⑬ PROVIDE 1 1/2" END COVER TO BARS D(#4) FROM OUTSIDE EDGE OF OVERALL LENGTH OF RAMP/SIDEWALK.

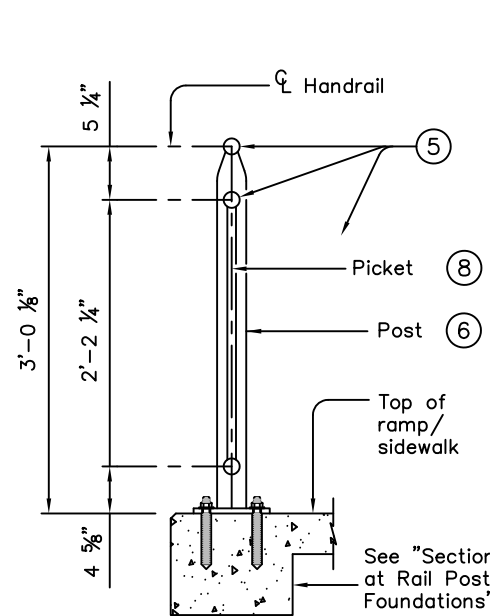

SECTION A - A
(Showing Handrail OPTION "1")

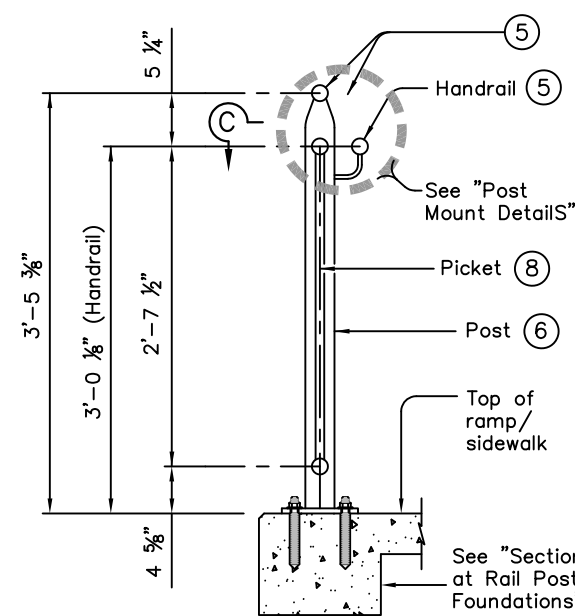

SECTION B - B
(Showing Handrail OPTION "2")

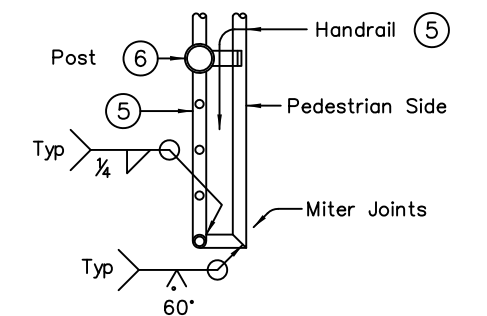

SECTION C - C
(Showing Handrail Termination)

The City of San Marcos Engineering and Capital Improvements	CURRENT AS OF 1/1/2022
RECORD COPY SIGNED BY LAURIE MOYER, P.E.	1/1/2020 ADOPTED
PEDESTRIAN HANDRAIL	
THE ARCHITECT/ENGINEER ASSUMES RESPONSIBILITY FOR APPROPRIATE USE OF THIS STANDARD.	STANDARD NO. 707S-1-SM 1 OF 3

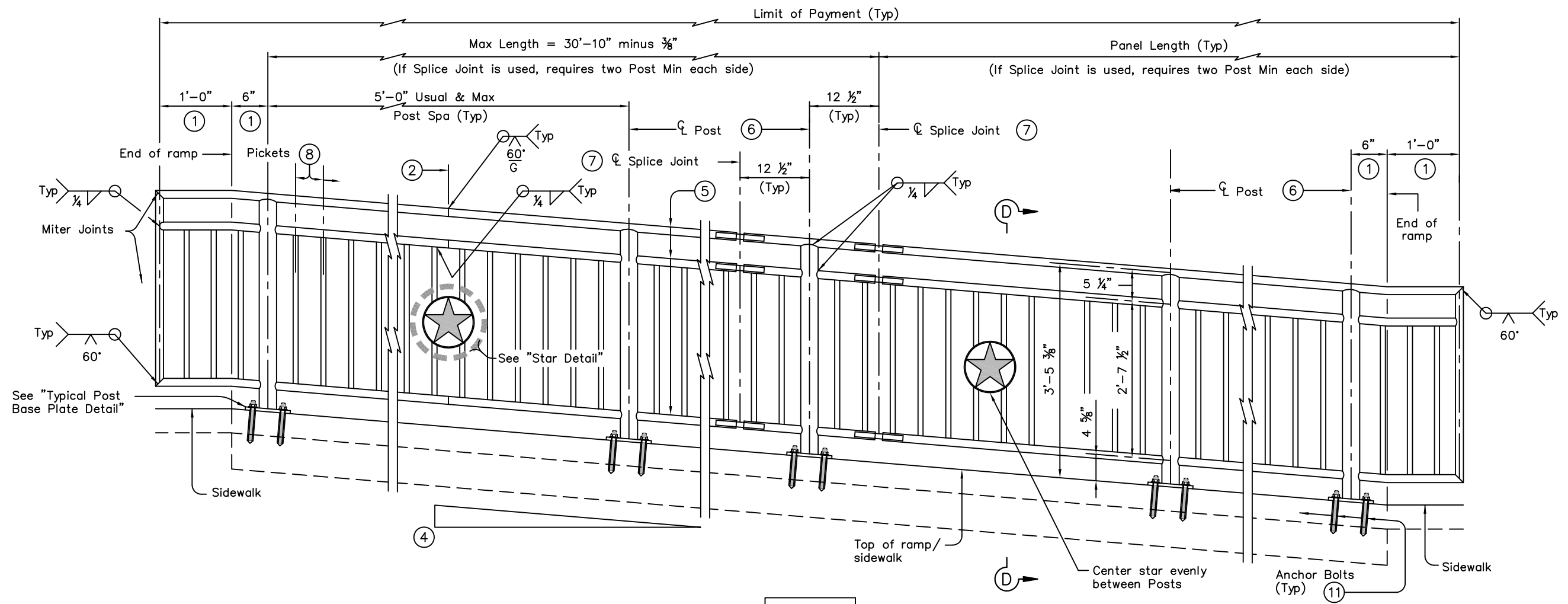

OPTION "3"

ELEVATION VIEW

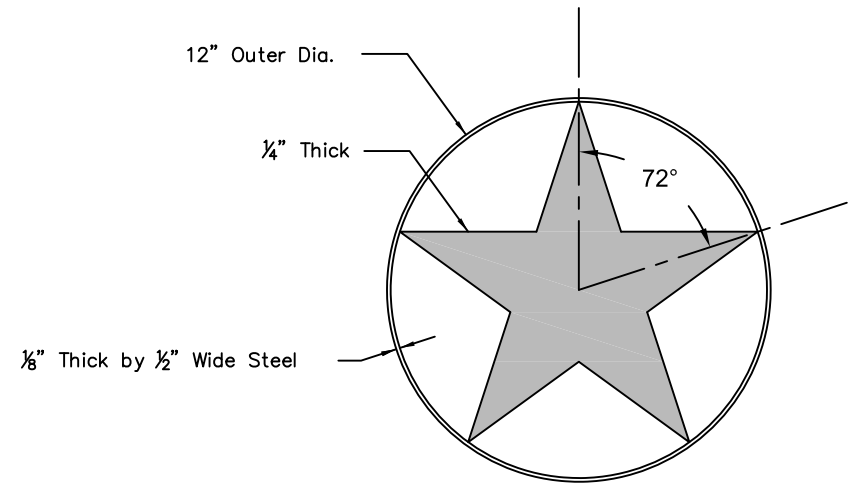

STAR DETAIL

The City of San Marcos Engineering and Capital Improvements		CURRENT AS OF 1/1/2022
RECORD COPY SIGNED BY LAURIE MOYER, P.E.		1/1/2020 ADOPTED
PEDESTRIAN HANDRAIL		
THE ARCHITECT/ENGINEER ASSUMES RESPONSIBILITY FOR APPROPRIATE USE OF THIS STANDARD.		STANDARD NO. 707S-1-SM 2 OF 3

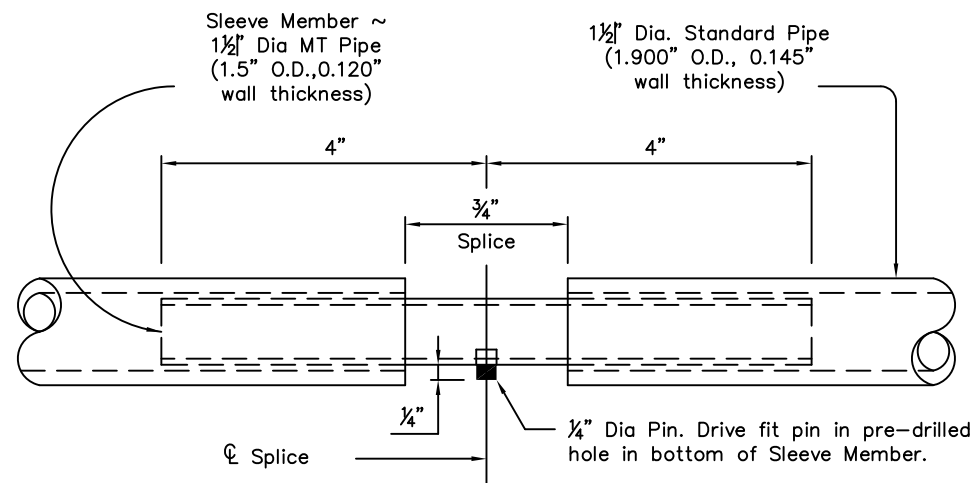

AT SPLICE JOINTS

HANDRAIL FABRICATION DETAILS

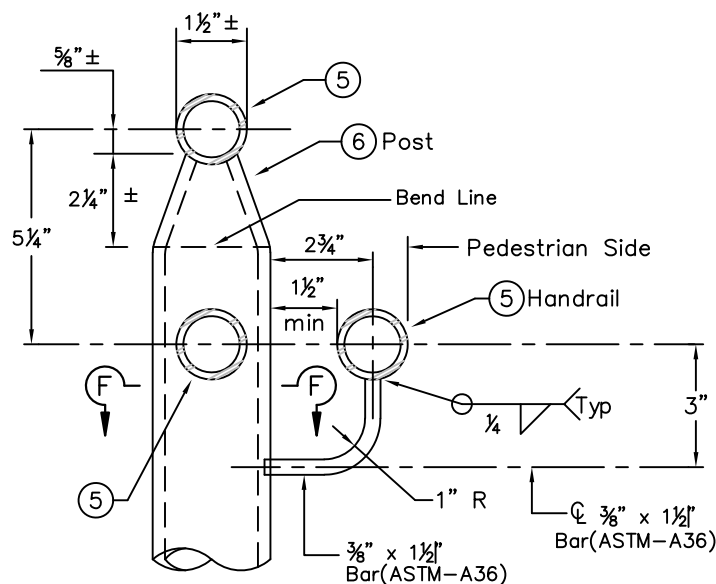

ELEVATION

POST MOUNT DETAILS

GENERAL NOTES

DESIGNED ACCORDING TO ADAAG, TEXAS ACCESSIBILITY STANDARDS, UNIFORM BUILDING CODE, AND AASHTO LRFD SPECIFICATIONS.

HANDRAIL ANCHORAGE DETAILS SHOWN ON THIS STANDARD MAY REQUIRE MODIFICATION FOR SELECT STRUCTURE TYPES. SEE APPROPRIATE DETAILS ELSEWHERE IN PLANS FOR THESE MODIFICATIONS.

PIPE WILL CONFORM TO ASTM-A53 GRADE B OR A500 GRADE B. STEEL PLATES AND STEEL BARS WILL CONFORM TO ASTM-A36. MECHANICAL TUBING (MT) WILL CONFORM TO ASTM A513 GRADE 1015 OR HIGHER. GALVANIZE ALL STEEL COMPONENTS EXCEPT REINFORCING STEEL UNLESS NOTED OTHERWISE.

CONCRETE FOR FOUNDATIONS WILL BE IN ACCORDANCE WITH ITEM 531 "SIDEWALKS". ALL REINFORCING STEEL MUST BE GRADE 60. BAR LAPS, WHERE REQUIRED, WILL BE AS FOLLOWS: UNCOATED ~ #4 = 1'-5" EPOXY COATED ~ #4 = 2'-1"

WHEN THE PLANS REQUIRE PAINTED STEEL, FOLLOW THE REQUIREMENTS FOR PAINTING GALVANIZED STEEL IN TXDOT ITEM 446, "CLEANING AND PAINTING STEEL". SLEEVE MEMBERS WILL RECEIVE GALVANIZATION AND ONLY GET FIELD PAINTED AFTER INSTALLATION UNLESS DIRECTED OTHERWISE BY ENGINEER.

EPOXY ANCHOR BOLTS FOR WALL MOUNT AND POST BASE PLATE WILL BE 5/8" DIA. ASTM A36 THREADED RODS WITH ONE HEX NUT AND ONE HARDENED STEEL WASHER AT EACH BOLT. 5/8" DIA. THREADED ROD EMBEDMENT DEPTH FOR WALL MOUNTS IS 3 1/2" AND EMBEDMENT DEPTH FOR POST BASE PLATE IS 5".

EMBED THREADED RODS INTO CONCRETE WITH A TYPE III (CLASS C) EPOXY MEETING THE REQUIREMENTS OF TXDOT DMS-6100, "EPOXIES AND ADHESIVES". MIX AND DISPENSE ADHESIVE WITH THE MANUFACTURER'S STATIC MIXING NOZZLE/DUAL CARTRIDGE SYSTEM. CORE DRILL HOLES (PERCUSSION DRILLING NOT PERMITTED).

AT THE CONTRACTOR'S OPTION THE POST BASE PLATE ANCHOR BOLTS MAY BECAST WITH THE RAMP/SIDEWALK (SEE CAST-IN-PLACE ANCHOR BOLT OPTIONS).

OPTIONAL CAST-IN-PLACE ANCHOR BOLTS WILL BE 5/8" DIA ASTM A307 GRADE A BOLTS (OR A36 THREADED RODS WITH ONE TACK WELDED HEX NUT EACH) WITH ONE HEX NUT AND ONE HARDENED STEEL WASHER AT EACH BOLT. EMBEDMENT DEPTH OF CAST-IN-PLACE BOLT WILL BE 8" FOR POST BASE PLATE.

HANDRAILS AND ANY WALL OR OTHER SURFACE ADJACENT TO THEM WILL BE FREE OF ANY SHARP OR ABRASIVE ELEMENTS.

SUBMIT SHOP DRAWINGS TO THE ENGINEER UNLESS OTHERWISE NOTED. FOR CURVED HANDRAIL APPLICATIONS, FABRICATE THE HANDRAIL TO THE CURVE IF RADIUS IS LESS THAN 600 FT. SHOP DRAWINGS ARE REQUIRED WHEN RAIL IS FABRICATED TO THE CURVE.

FOR ALL HANDRAILS, ERECTION DRAWINGS WILL BE SUBMITTED TO THE ENGINEER FOR APPROVAL TO ENSURE PROPER INSTALLATION.

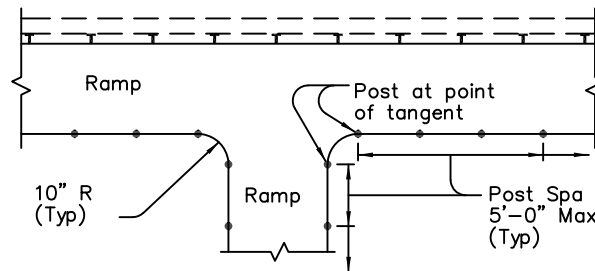

RAMP INTERSECTION

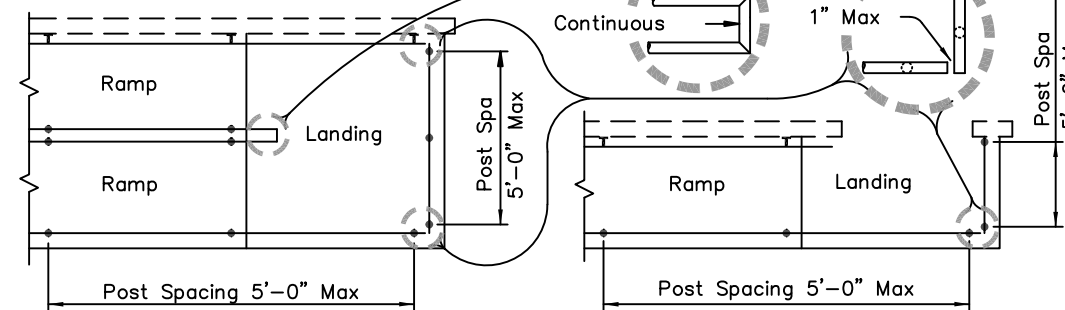

MULTI-LEVEL RAMP

SINGLE-LEVEL RAMP

PLAN SHOWING RAIL AT RAMP CONDITIONS

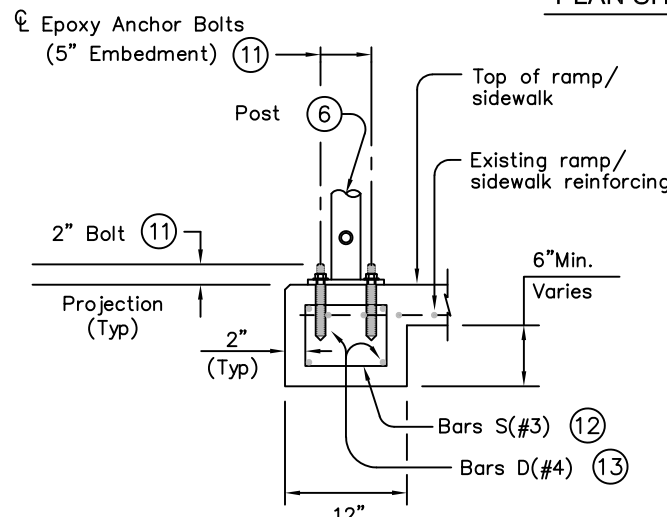

WITHOUT CURB

SECTION AT RAIL POST FOUNDATIONS

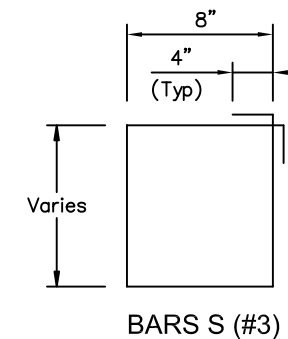

BARS S (#3)

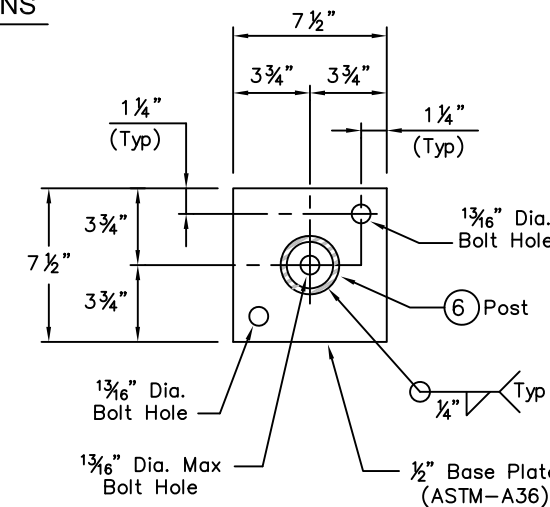

TYPICAL POST BASE PLATE DETAIL

5/8" Dia. Hex Head Anchor Bolt (ASTM-A307) or Threaded Rod (ASTM-A36) with one Hardened Steel Washer placed under Hex Nut. One additional Hex Nut will be furnished for each Threaded Rod.

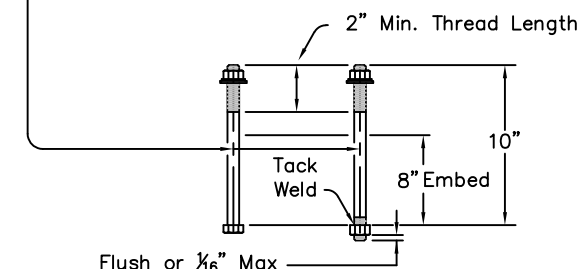

CAST-IN-PLACE ANCHOR BOLT OPTIONS

(Used for Post Base Plate only)

DRAWINGS WILL SHOW HANDRAIL MOUNT LOCATIONS WITH BOLTS SETTING, SPACING, RAMP SLOPE, AND/OR SPLICE JOINT LOCATIONS, AND HANDRAIL LENGTHS WITH IDENTIFICATION SHOWING WHERE EACH HANDRAIL GOES ON THE LAYOUT.

PAYMENT FOR CONCRETE SIDEWALKS OR CURB RAMPS WILL BE PAID FOR IN ACCORDANCE WITH ITEM 531 "SIDEWALKS".

PAYMENT FOR ALL ITEMS SHOWN, INCLUDING RAIL POST FOUNDATION, IS TO BE INCLUDED IN UNIT PRICE BID IN ACCORDANCE WITH ITEM 450 "RAILING" OF THE TYPE SPECIFIED.

ALL EXPOSED EDGES WILL BE ROUNDED OR CHAMFERED TO APPROXIMATELY 1/8" BY GRINDING.

HANDRAIL FINISH NOTES

- GALVANIZED SHALL FOLLOW TXDOT ITEM 445 GALVANIZING.
- FOR COLOR PAINTING FOLLOW FINISHING NOTES 3 TO 5.
- PRIOR TO PAINTING, COMPONENTS SHALL BE DEGREASED USING A FULL SPRAY SYSTEM. HAND WIPED CLEANING IS NOT ACCEPTABLE. FOLLOWING DEGREASING, AND PRIOR TO PAINTING, COMPONENTS SHALL BE DRIED IN A BAKING OVEN.
- THE PAINT SHALL BE NON-TOXIC, LEAD-FREE, ELECTROSTATICALLY APPLIED POWDER COAT. LIQUID SPRAY OR DIP TYPE APPLICATION IS NOT ACCEPTABLE. THE PAINT SHALL BE BAKE CURED IN AN OVEN SYSTEM, NOT AIR-DRIED.
- PAINT SHALL BE SHERWIN WILLIAMS, ENAMEL, SW 6258 "TRICORN BLACK", SEMI-GLOSS FINISH; OR APPROVED EQUAL UNLESS OTHERWISE STATED IN THE PLANS.

The City of San Marcos Engineering and Capital Improvements CURRENT AS OF 1/1/2022

RECORD COPY SIGNED BY 1/1/2020

Laurie Moyer, P.E. ADOPTED

PEDESTRIAN HANDRAIL

THE ARCHITECT/ENGINEER ASSUMES RESPONSIBILITY FOR APPROPRIATE USE OF THIS STANDARD. STANDARD NO. 707S-1-SM